

The PLU family provides a light source uniform and diffuse whit a great power, as backlight provide a contrast between the profile and the bottom of the piece.



LIGHTING TECHNIQUE

Lighting mode: Backlight, Brightfield
Light source: 49 LEDs
Colour (nm): See table 1
LED life: Until 100.000 hours

MECHANICAL

LxWxH: See external plane
Mounting: 6 (M4)
Housing material: Black anodized aluminium
Weight: 180 g

ELECTRICAL

Max. power supply: 24VDC (Continuous models)
Max. consumption: 160mA
Wire include: VCB018 (See table 2)
Wire terminal: Brown -> 24VDC
 Blue -> 0V (GND)

ENVIRONMENTAL

Max. Operating Humidity: 95% non-condensing
Operating temp: 0..40°C
Storage temp: 0..60°C

EXTERNAL PLANE

ALL UNITS IN MILLIMETERS

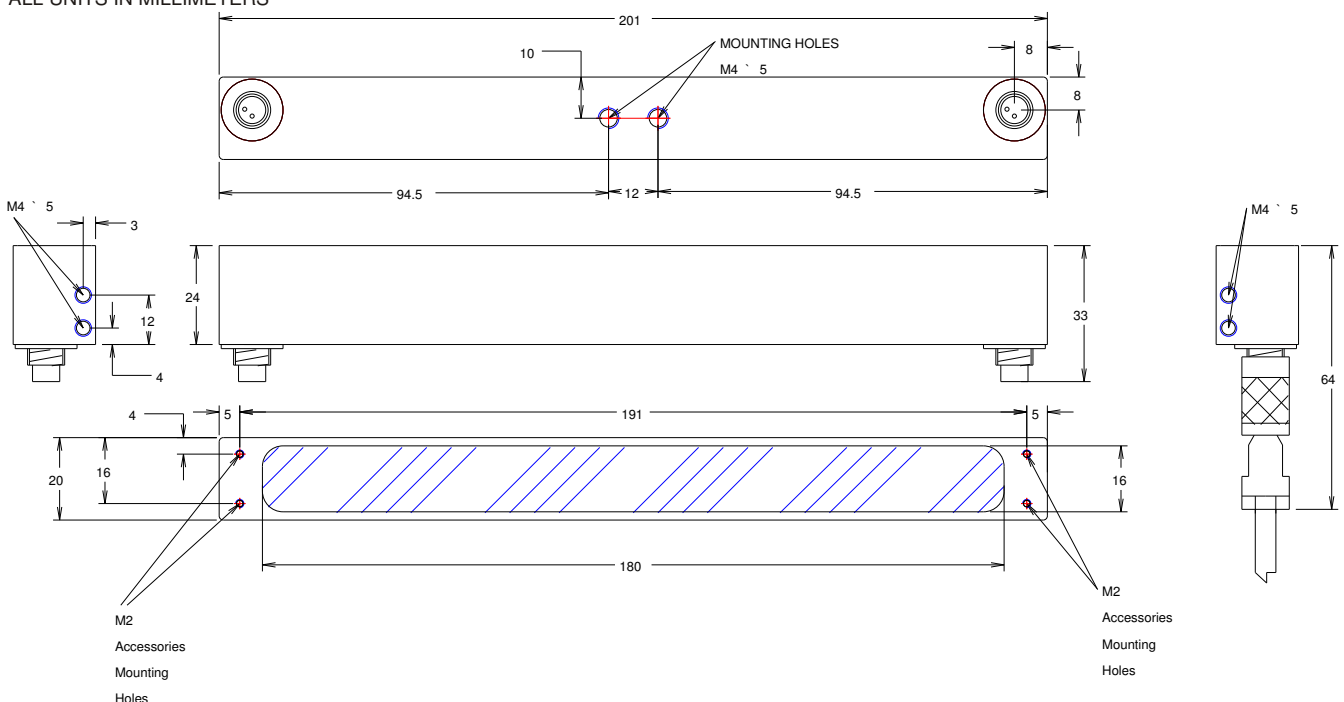

PLU

MODELS

Table 1.

Ligth colour	Wavelength	Type	Reference
Blue	470nm	Continuous	PLU1802A-470C
Blue	470nm	Strobe	PLU1802A-470S
Green	525nm	Continuous	PLU1802A-525C
Green	525nm	Strobe	PLU1802A-525S
Red	630nm	Continuous	PLU1802A-630C
Red	630nm	Strobe	PLU1802A-630S
White	-----	Continuous	PLU1802A-W00C
White	-----	Strobe	PLU1802A-W00S
Others	-----	-----	Consult

COMPLEMENTS

Table 2.

Complement	Type	Reference
Wire 1.8 m	Wire	VCB018
Wire 2.5 m	Wire	VCB025
Wire 4.0 m	Wire	VCB040
Strobe controller whit 3 outputs	Strobe	VST33I

LIGHTING MODES

UNIFORM DIFFUSE BACK LIGHT

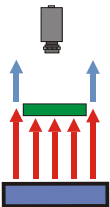

The camera faces on the source of light, showing a uniform white surface. Any object interposed between the camera and the source of light produces a shadow detected by the camera as a black shape on the white background, obtaining maximum contrast. Used to measures the profiles of the pieces and also the transmission and impurities in transparent and traslucid objects.

BRIGHT FIELD

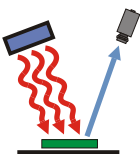

The light source is uniform and diffuse, and falls on a little angle of the reflecting surface of the object to inspect. The camera is placed in the same angle so that we can have a reflected image of the light source in the surface of the inspected object. A dark spot will appear in the image taken by the camera if there is any imperfection in the object. The dark spot is due to the variation of the angle of reflection that produces the imperfection on regard to the angle of the incident light, losing the reflect of the lighting source.