

High intensity led projector, to cover wide zones or to illuminate from great distances.

Depending of the set collocation we can use them as a darkfield (standing out the small relief and cracks) or like a downlight illuminator.

The most typical applications of this light is the measure of objects or the stand out of edges.



LIGHTING TECHNIQUE

Lighting mode: Direct
Light source: 30 high intensity LEDs
Colour (nm): See table 1
LED life: Until 100.000 hours

MECHANICAL

LxWxH: See external plane
Mounting: 6 (M4)
Housing material: Black anodized aluminium
Weight: 130 g

ELECTRICAL

Max. power supply: 24VDC (Continuous models)
Max. consumption: 150mA (White Model)
Wire include: VCB018 (See table 2)
Wire terminal: Brown -> 24VDC
 Blue -> 0V (GND)

ENVIRONMENTAL

Max. Operating Humidity: 95% non-condensing
Operating temp: 0..40°C
Storage temp: 0..60°C

EXTERNAL PLANE

ALL UNITS IN MILLIMETERS

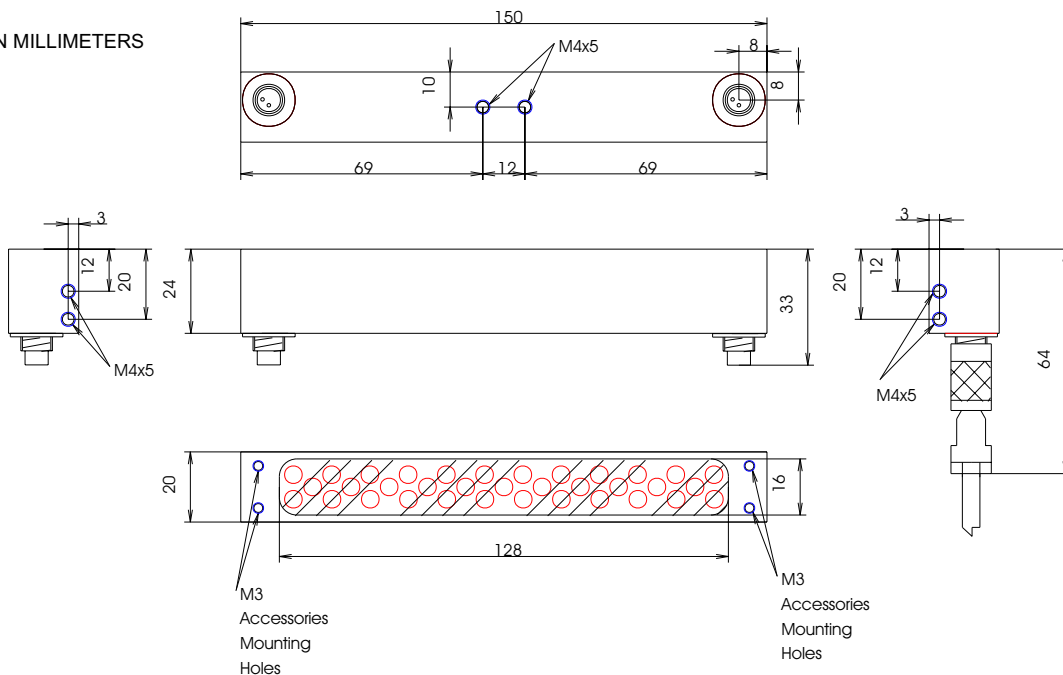

PLD

MODELS

Table 1.

Ligth colour	Wavelength	Type	Reference
UV	400nm	Continuous	PLD1302A-400C
UV	400nm	Strobe	PLD1302A-400S
Blue	470nm	Continuous	PLD1302A-470C
Blue	470nm	Strobe	PLD1302A-470S
Green	525nm	Continuous	PLD1302A-525C
Green	525nm	Strobe	PLD1302A-525S
Red	630nm	Continuous	PLD1302A-630C
Red	630nm	Strobe	PLD1302A-630S
Near infrared	880nm	Continuous	PLD1302A-880C
Near infrared	880nm	Strobe	PLD1302A-880S
Infrared	940nm	Continuous	PLD1302A-940C
Infrared	940nm	Strobe	PLD1302A-940S
White	-----	Continuous	PLD1302A-W00C
White	-----	Strobe	PLD1302A-W00S
Others	-----	----	Consult

COMPLEMENTS

Table 2.

Complement	Type	Reference
Wire 1.8 m	Wire	VCB018
Wire 2.5 m	Wire	VCB025
Wire 4.0 m	Wire	VCB040
Strobe controller whit 3 outputs	Strobe	VST33I
Polarized filter	Polarizer	VPFPLD1302A

LIGHTING MODES

DOWN LIGHT PUNCTUAL LIGHTING (HARD)

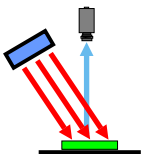

The light produced by the leds array reaches directly the object. It produces a great contrast and emphasizes the textures, relief's and fissures of the lighted object. Because any relief, even a small one, produces a very defined shadow.

The incidence light angle regarding the lighting plane will determine the degree of the relief's projection. For very small angles regarding the horizontal, the light will produce shadows in the reliefs of the piece.

For angles near 90° with regard to the horizontal, the shadow will be visible just in great reliefs.

Its use is ideal for the detection of pieces and objects and its correct placement, in the detection of edges, scratches or fissures in a certain direction.