

Dark field allows the illumination of objects by using a very little angle, highlighting any surface faults. So that, in cracked or raised surfaces, the trajectory of the light produces bright areas.

Our system covers an area up to 35mm working at a distance between 8mm and 20 mm.

The most typical applications for this lighting are for the inspection of metallic objects with small defects or fissures.



**LIGHTING TECHNIQUE**

**Lighting mode:** Darkfield  
**Light source:** 60 high intensity LEDs  
**Colour (nm):** See table 1  
**LED life:** Until 100.000 hours

**MECHANICAL**

**LxWxH:** See external plane  
**Mounting:** 8 ( ø5.1 mm through)  
**Housing material:** Black anodized aluminium  
**Weight:** 380 g

**ELECTRICAL**

**Max. power supply:** 24VDC (Continuous models)  
**Max. consumption:** 300mA  
**Wire include:** 1.8m  
**Wire terminal:** Brown -> 24VDC  
 Blue -> 0V (GND)

**ENVIRONMENTAL**

**Max. Operating Humidity:** 95% non-condensing  
**Operating temp:** 0..40°C  
**Storage temp:** 0..60°C

**EXTERNAL PLANE**

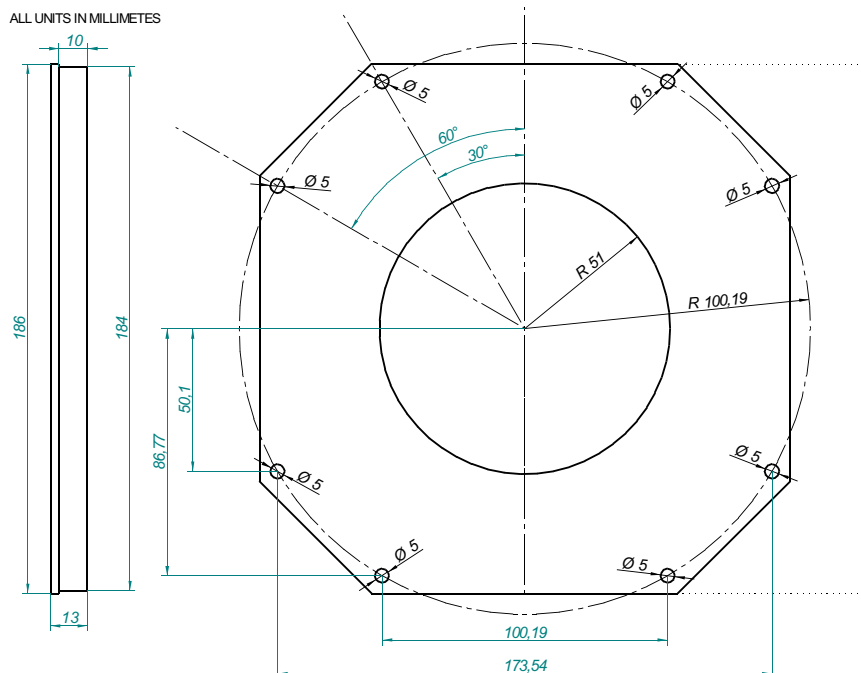

DKL

### MODELS

Table 1.

Ligth colour	Wavelength	Type	Reference
UV	400nm	Continuous	DKL1810A-400C
UV	400nm	Strobe	DKL1810A-400S
Blue	470nm	Continuous	DKL1810A-470C
Blue	470nm	Strobe	DKL1810A-470S
Green	525nm	Continuous	DKL1810A-525C
Green	525nm	Strobe	DKL1810A-525S
Red	630nm	Continuous	DKL1810A-630C
Red	630nm	Strobe	DKL1810A-630S
Near infrared	880nm	Continuous	DKL1810A-880C
Near infrared	880nm	Strobe	DKL1810A-880S
Infrared	940nm	Continuous	DKL1810A-940C
Infrared	940nm	Strobe	DKL1810A-940S
White	-----	Continuous	DKL1810A-W00C
White	-----	Strobe	DKL1810A-W00S
Others	-----	----	Consult

### COMPLEMENTS

Table 2.

Complement	Type	Reference
Strobe controller with 3 outputs	Strobe	VST33I

### LIGHTING MODES

#### DARK FIELD LIGHT

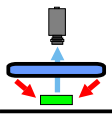

Direct light of high intensity that falls on the object with very little angle with regards to the surface where it lies. In that way cracked or raised surfaces interfere in the trajectory of the light producing bright areas. The most common applications for this technique are those to verify engravings, (laser), or defects on the surface.